

ДОНЫШКИ

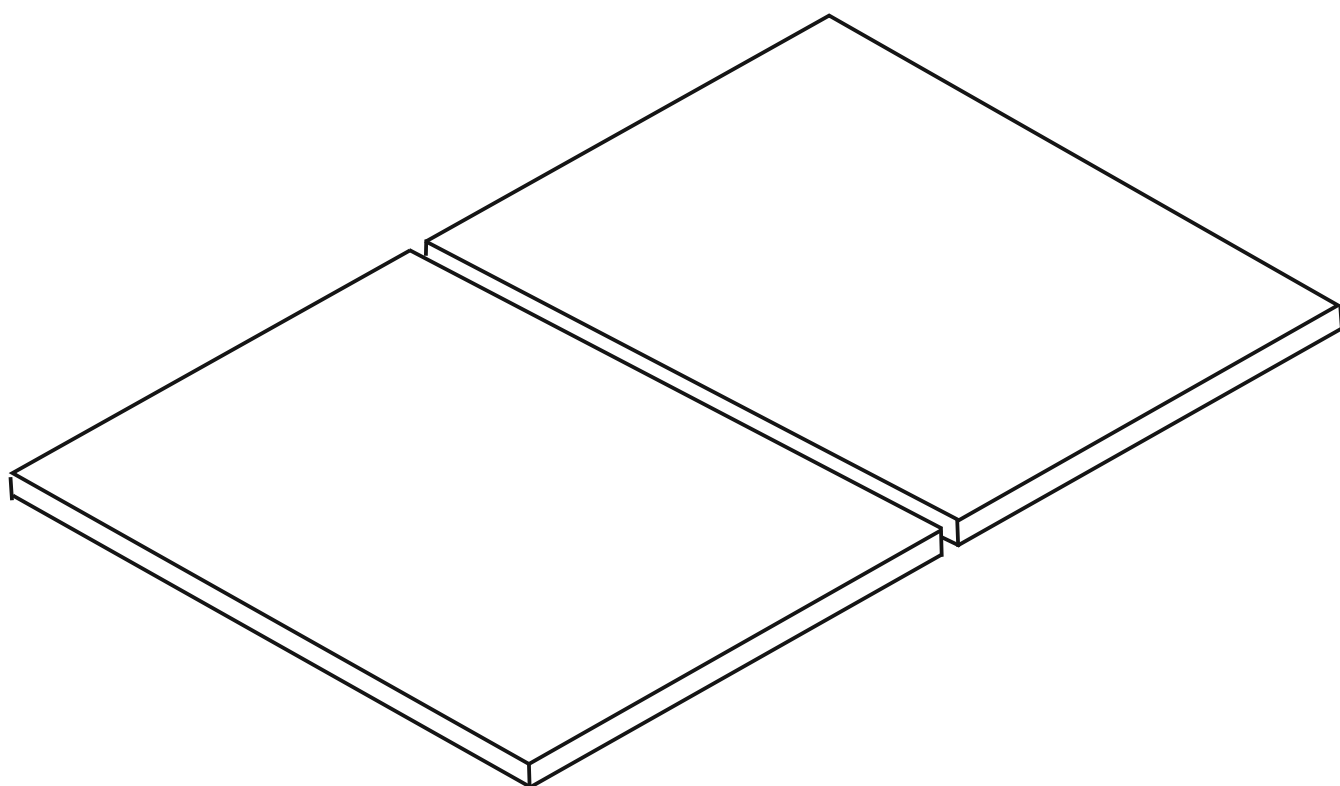

PROXSON

правила хорошего сна

Φ1

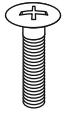

12x
16x*

Φ2

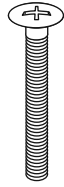

2x
4x*

Φ3



4x

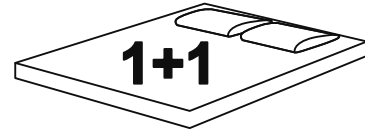

A1
2x

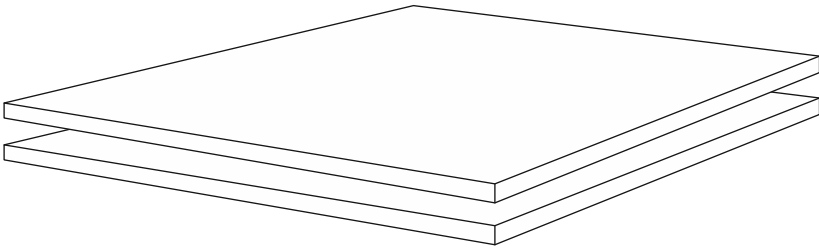

A3
7x
10x*

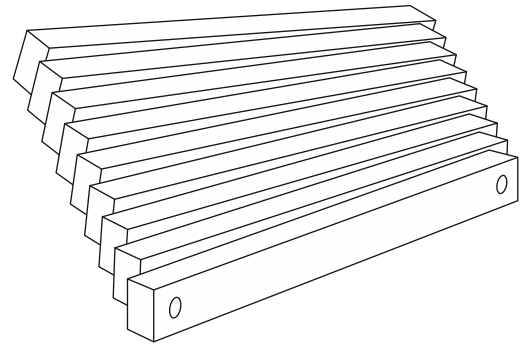

A2*
1x

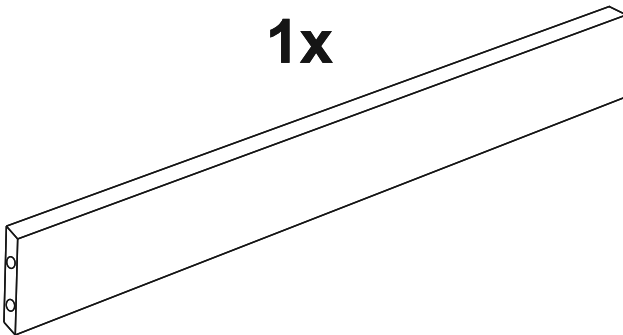

A4
1x
2x*

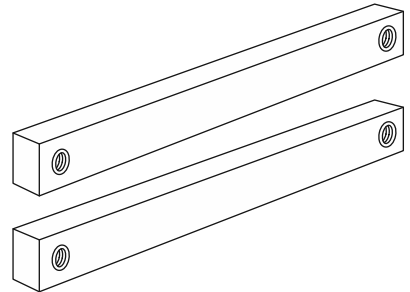

1

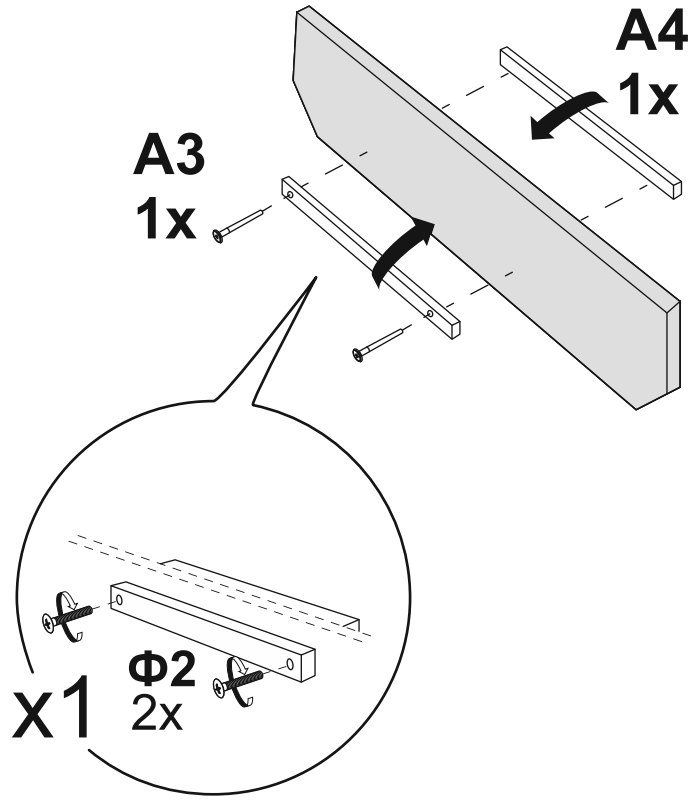

1*

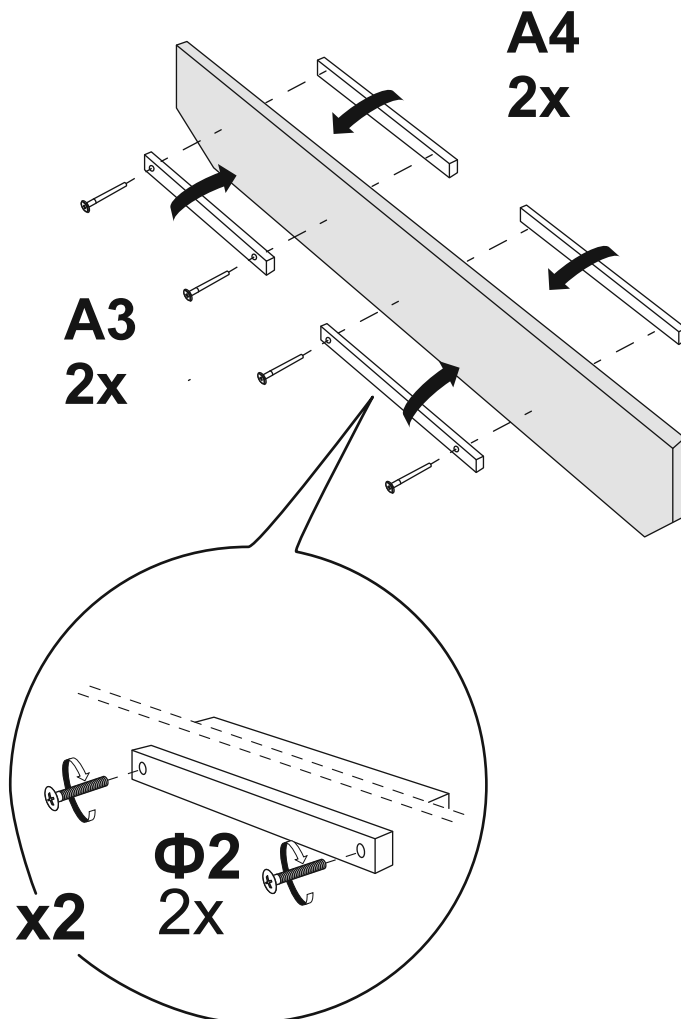

2*

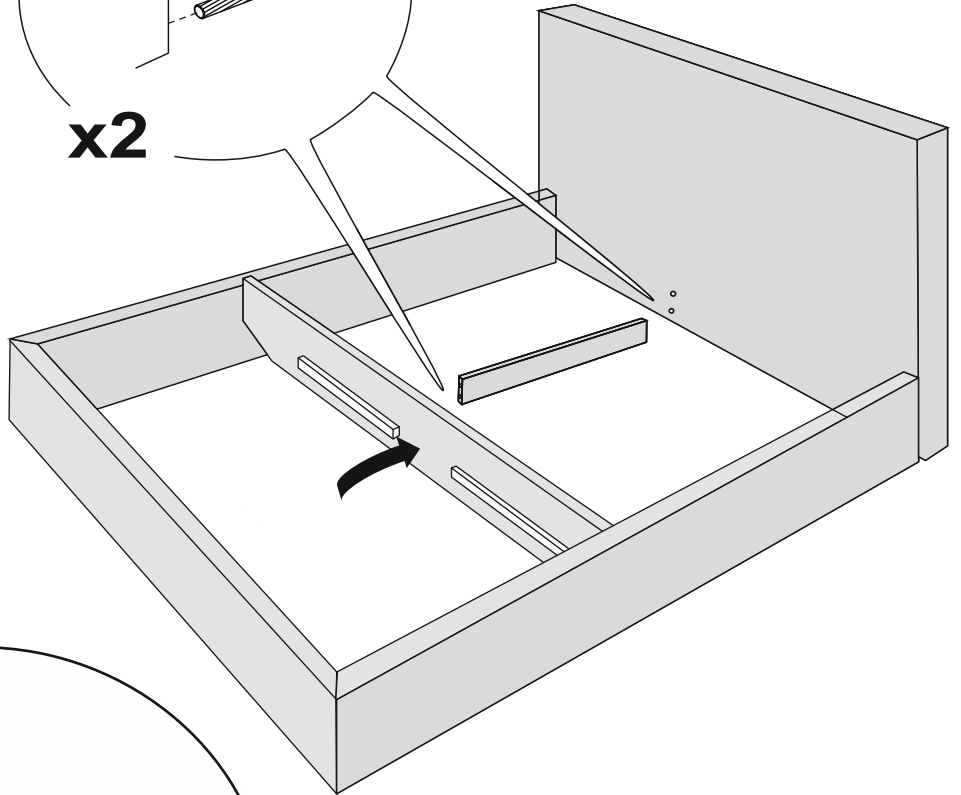
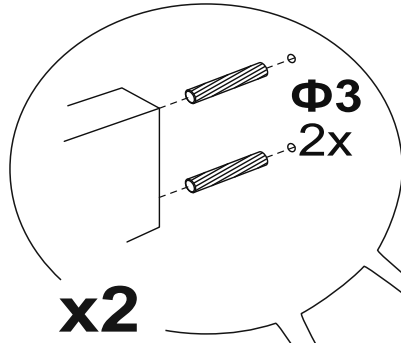

3

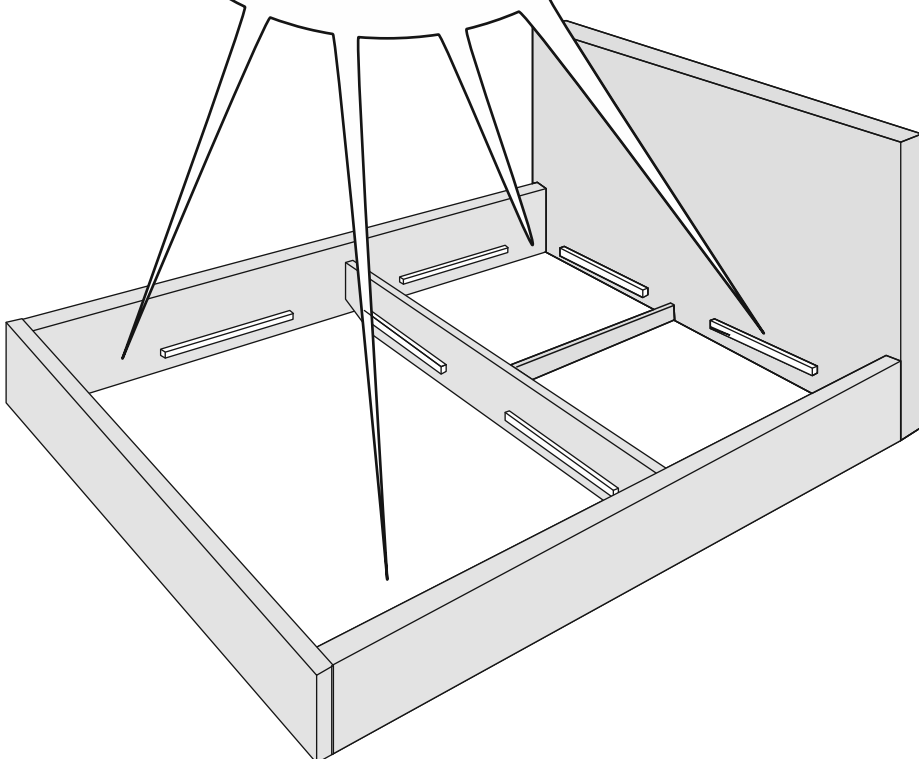
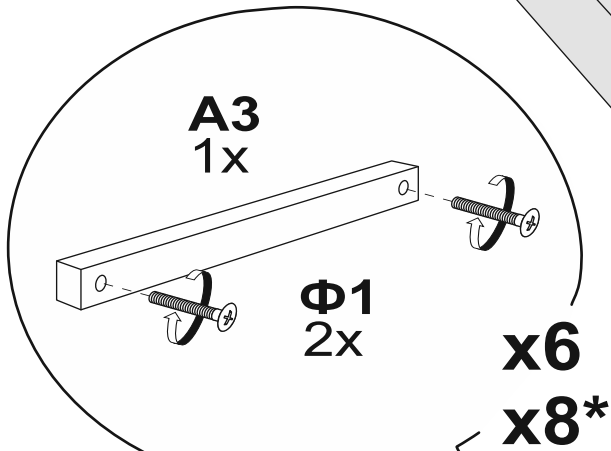

4

A1
2x

